

Numatic International Spare Parts

Model No: TTV5565 Charger/Chassis/Pedal Assembly

234760
DRAWING: DRW-7099 ISS: A01
15/12/2010

NB: FOR WIRING SEE DRAWING: DRW-5329

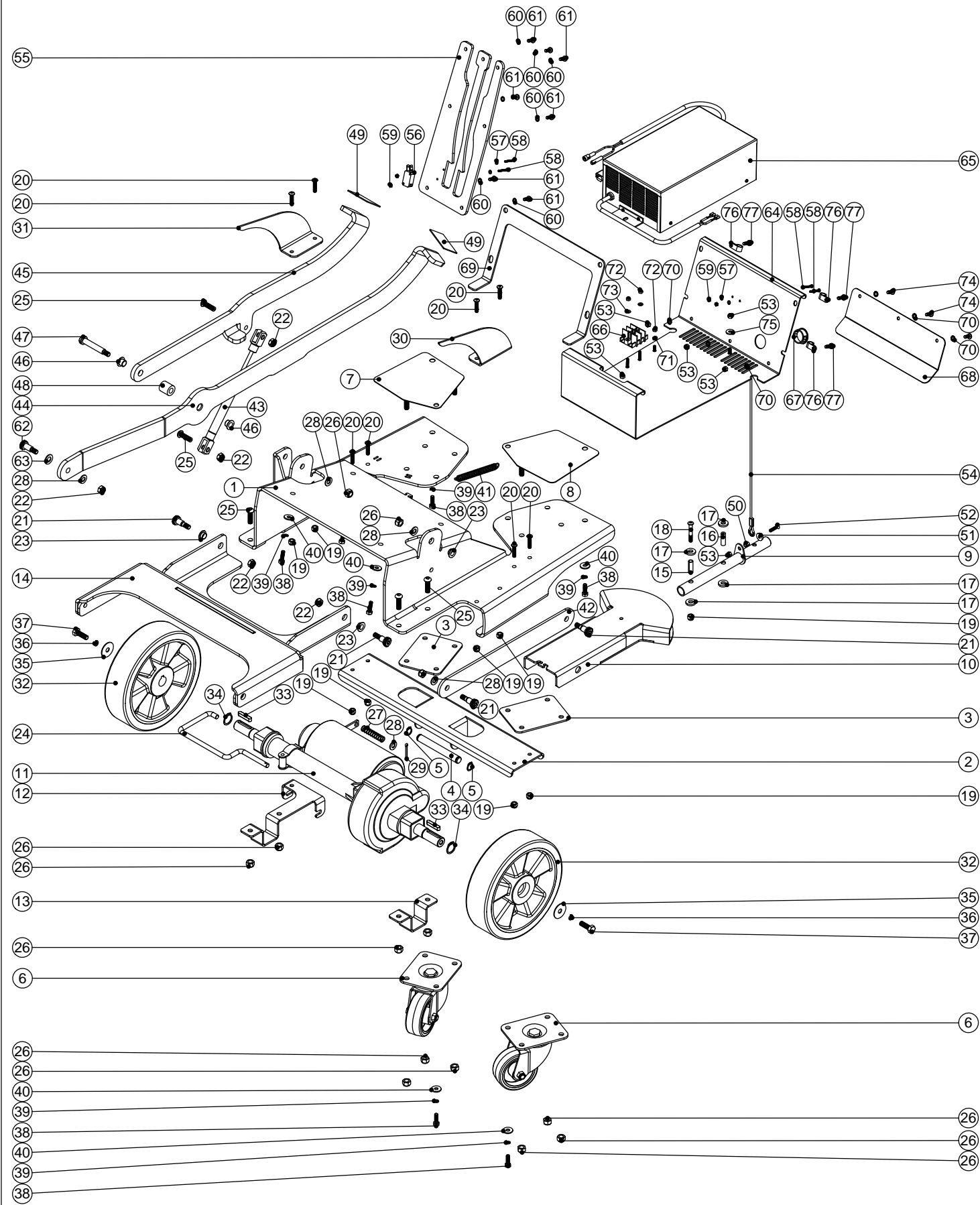

Numatic International Spare Parts

Model No: TTV5565 Charger/Chassis/Pedal Assembly

POS:	ITEM NO:	DESCRIPTION:	COMMENTS:
1	404064	CHASSIS WELD ASSEMBLY (PAINTED GREY)	
2	404083	FLOOR TOOL LIFTING BRACKET (PAINTED GREY)	
3	329581	CASTOR ADAPTOR SPACER	
4	206965	PIVOT AXLE	
5	219151	13MM EXTERNAL CIRCLIP	
6	206728	CASTOR	
7	303980	CASTOR PLATE (RIGHTHAND SIDE)	
8	303981	CASTOR PLATE (LEFTHAND SIDE)	
9	303946	FLOOR TOOL LIFTING TUBE WELDED ASSEMBLY	
10	303932	FLOOR TOOL LIFTING PLATE WELDED ASSEMBLY	
11	206724	TRANSAXLE	
12	392089	TRANSAXLE CLAMP AND BRAKE LEVER BRACKET	
13	329497	TRANSAXLE MOUNTING BRACKET	
14	404065	BRUSH DECK LIFTING LINK WELDED ASSEMBLY (PAINTED GREY)	
15	206954	SPIRO SPACER	
16	206963	VERTICAL NYLON SPACER	
17	206964	SLIDE NYLON SPACER	
18	219807	M6 X 40MM LONG SOCKET BUTTON HEAD BOLT	
19	219088	M6 NYLON INSERT NUT	
20	291010	M6 X 20MM LONG SOCKET BUTTON HEAD SCREW	
21	208313	M8 X 10 X 12 SHOULDER BOLT	
22	219857	M8 NYLON INSERT HALF NUT	
23	208330	IGUS BEARING (GFM 101206)	
24	303769	BRAKE LEVER	
25	219555	M8 X 25MM LONG SOCKET BOLT	
26	219078	M8 NYLON INSERT NUT	
27	219326	50MM LONG COMPRESSION SPRING	
28	219010	M8 FORM A WASHER	
29	219171	3.2MM X 28MM SPLIT COTTER PIN	
30	404075	WHEEL ARCH BRACKET (LEFTHAND SIDE) (PAINTED GREY)	
31	404082	WHEEL ARCH BRACKET (RIGHTHAND SIDE) (PAINTED GREY)	
32	206727	200MM DIAMETER X 50MM WIDE ALLOY WHEEL	
33	206744	6MM X 6MM X 32MM FEATHER KEY	
34	219889	19MM HEAVY DUTY CIRCLIP	
35	219877	M8 X 30 STAINLESS STEEL WASHER	
36	219898	M8 SINGLE COIL STAINLESS STEEL WASHER	
37	219893	M8 X 25MM LONG HEXAGONAL STAINLESS STEEL BOLT	
38	219455	M6 X 20MM LONG HEX HEAD SCREW	
39	219718	M6 STAINLESS STEEL SPRING WASHER	
40	219008	M6 FORM G WASHER	
41	20695V	SPRING	
42	404066	BRUSH DECK LIFTING LINK (PAINTED GREY)	
43	208325	GAS STRUT	
44	404060	FOOT PEDAL (ZINC PLATED)	
45	404061	EXTRA PRESSURE DECK ARM (ZINC PLATED)	
46	208331	IGUS BEARING (GFM 101209)	
47	208333	M8 X 10 X 50 SHOULDER BOLT	
48	208350	NYLON SPACER I/D 10.2MM X O/D 20.0MM X LENGTH 21.0MM	
49	391372	FOOT PEDAL PAD	
50	219508	SPIROL SPACER	
51	219573	SCREW INSULATOR	
52	219331	M5 X 20MM LONG POZI PAN COUNTERSUNK SCREW	
53	219076	M5 NYLON INSERT NUT	
54	208204	495MM LONG LIFTING LINK WIRE	
55	404085	DECK LIFT GUIDE (ZINC PLATED)	
56	229483	SNAP ACTION SWITCH	
57	219237	M3 FORM A WASHER	
58	219519	M3 X 25MM LONG POZI PAN SCREW	
59	219070	M3 NYLON INSERT NUT	
60	219016	M5 SHAKEPROOF WASHER	
61	219049	M5 X 12MM LONG POZI PAN SCREW	
62	208332	M8 X 10 X 16 SHOULDER BOLT	
63	219903	M10 FORM A STAINLESS STEEL WASHER	
64	404062	CHARGER PLATE WELDED ASSEMBLY (PAINTED GREY)	
65	230186	220-240V MENTZER 35 AMP CHARGER (190MM WIRE VERSION)	
	230185	110-120V MENTZER 30 AMP CHARGER (190MM WIRE VERSION)	
66	220114	2 WAY TERMINAL BLOCK	
67	206314	WINDOW PLUG	
68	404086	CHARGER SPLASH SKIRT (PAINTED GREY)	
69	208337	CHARGER PLATE GASKET	
70	291020	M5 STAINLESS STEEL EXTERNAL SHAKEPROOF LOCK WASHER	
71	219075	M4 FULL NUT	
72	219083	M4 NYLON INSERT NUT	
73	219206	M4 FORM A WASHER	
74	219740	M5 X 12MM LONG STAINLESS STEEL POZI PAN SCREW	
75	219005	M5 FORM G WASHER	
76	219393	P CLIP	
77	219045	M5 X 16MM LONG POZI PAN SEMS SCREW	

Numatic International Spare Parts

Model No: TTV5565 Bottom Tank/Pump/Batteries/Floor Tool Lifting Assy

234758
DRAWING: DRW-6836 ISS: A01
20/12/2010
21/10/2010

NB: FOR WIRING SEE DRAWING: DRW-5329

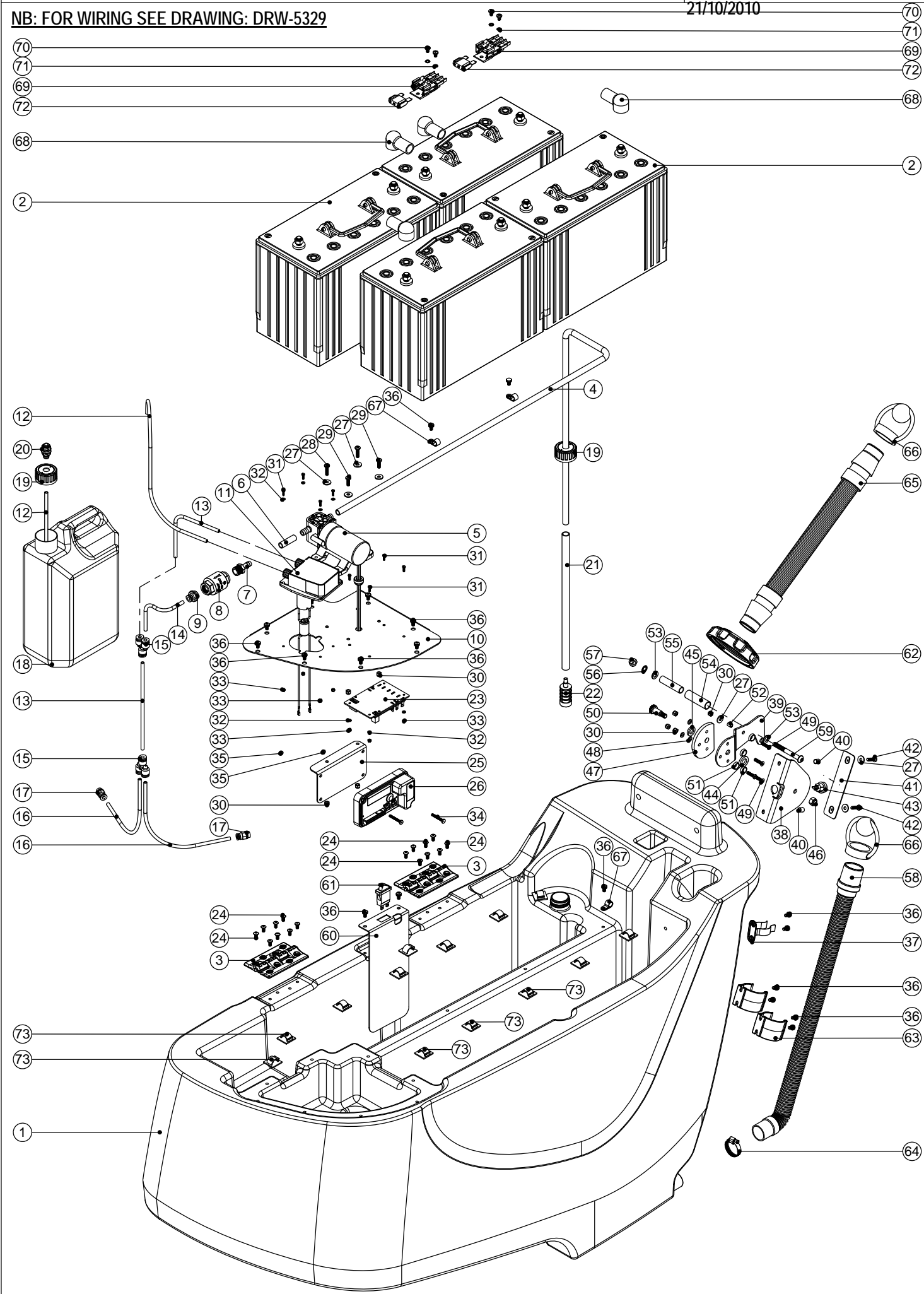

Numatic International Spare Parts

Model No: TTV5565 Bottom Tank/Pump/Batteries/Floor Tool Lifting Assy

POS:	ITEM NO:	DESCRIPTION:	COMMENTS:
1	237112	GREY BOTTOM TANK MOULDING	
2	205112	100 AMP/HOUR REPLACEMENT BATTERY (C/W PACKING FOR 230138 BATTERY)	
3	303954	PLASTIC HINGE ASSEMBLY	
4	303949	1300MM LONG X 8MM I/D X 11MM O/D CLEAR PVC HOSE	
5	321572	WATER PUMP & LEAD ASSEMBLY C/W GROMMET & PUSH ON TERMINALS	
6	303936	37MM LONG X 8MM I/D X 11MM O/D CLEAR PVC HOSE	
7	219389	3/8" BSP HOSE TAIL	
8	206874	YORK 103 CHECK VALVE	
9	208446	3/8 INCH MALE PUSH IN STUD C/W 6MM PUSH FIT	
10	392048	PUMP COVER PLATE	
11	321569	DETERGENT PUMP & SOLDERED LEAD ASSEMBLY C/W PUSH ON TERMINALS	
12	391358	315MM LONG X 4MM I/D X 6MM O/D FLEXIBLE NYLON TUBE	
13	303938	200MM LONG X 4MM I/D X 6MM O/D FLEXIBLE NYLON TUBE	
14	303952	165MM LONG X 4MM I/D X 6MM O/D FLEXIBLE NYLON TUBE	
15	208367	8.0mm Y CONNECTOR	
16	303940	340MM LONG X 4MM I/D X 6MM O/D FLEXIBLE NYLON TUBE	
17	208369	1/4" BSP TO 6MM PUSHFIT MALE STUD	
18	208320	5 LITRE PLASTIC CONTAINER	
19	303827	PROCESSED BLUE CAP	
20	208032	6MM BULKHEAD CONNECTOR	
21	391357	390MM LONG BLACK PVC TUBE	
22	208360	WEIGHTED FILTER	
23	208311	DC DRIVE PCB WITH DETERGENT ASSEMBLY ASSEMBLED	
24	291004	M5 X 10MM LONG STAINLESS STEEL BUTTON HEAD SCREW	
25	404071	PCB MOUNTING PLATE - PAINTED GREY	
26	208342	MOTOR CONTROLLER (D51341)	
27	219005	M5 FORM G WASHER	
28	219054	M5 X 20MM LONG POZI PAN SCREW	
29	219050	M5 X 16MM LONG POZI PAN SCREW	
30	219076	M5 NYLON INSERT NUT	
31	219236	M3 X 10MM LONG SLOT SCREW	
32	219237	M3 FORM A WASHER	
33	219070	M3 NYLON INSERT NUT	
34	219321	M4 X 30MM LONG POZI PAN SCREW	
35	219083	M4 NYLON INSERT NUT	
36	219047	M5 X 10MM LONG POZI PAN SEMS SCREW	
37	206818	HOSE CLIP	
38	392058	FLOOR TOOL LIFTING BRACKET (2)	
39	392057	FLOOR TOOL LIFTING BRACKET	
40	219843	6MM I/D X 9.5MM LONG SPIROL SPACER (STAINLESS STEEL)	
41	392105	FLOOR TOOL SWITCH SKID PLATE	
42	219546	M5 X 20MM LONG POZI PAN SEMS SCREW	
43	229454	HANDLE SWITCH	
44	229346	SPACER	
45	219964	NYLON WASHER (18MM O/D X 10.4MM I/D X 3MM THICK)	
46	219078	M8 NYLON INSERT NUT	
47	392082	FLOOR TOOL LIFTING LEVER SWITCH PLATE	
48	219003	M5 FORM A STEEL WASHER	
49	219331	M5 X 20MM LONG POZI PAN COUNTERSUNK SCREW	
50	208332	M8 X 10 X 16 SHOULDER BOLT	
51	219573	SCREW INSULATOR	
52	219508	SPIROL SPACER	
53	219578	M8 FORM A STAINLESS STEEL WASHER	
54	391131	53MM LONG BLACK NYLON TUBE	
55	391093	52MM LONG VAC MOTOR SPACER	
56	219018	M8 SHAKEPROOF WASHER	
57	219632	M8 STAINLESS STEEL DOME NUT	
58	213025	600MM - 630MM LONG DUMP HOSE ASSEMBLY	
59	219806	M8 X 70MM LONG SOCKET BUTTON HEAD BOLT	
60	404084	TANK LIFT SWITCH PLATE (PAINTED GREY)	
61	208442	DOOR SWITCH	
62	237174	FILLER CAP (WITH MIDDLE HOLE)	
63	229762	HOSE CLIP MOULDING	
64	219674	30/40MM DIAMETER STAINLESS STEEL JUBILEE CLIP	
65	206842	420MM LONG BLACK STRETCH HOSE C/W CUFFS	
66	206111	HOSE CLOSURE	
67	219393	P CLIP	
68	206861	RED PVC TERMINAL CAP	
69	230102	FUSE HOLDER RATED AT 60 AMPS	
70	219864	M5 X 8MM LONG POZI PAN SCREW	
71	219016	M5 SHAKEPROOF WASHER	
72	221047	40 AMP MAXI FUSE	
73	220403	CABLE CLIP	

Numatic International Spare Parts

Model No: TTV5565 Top Tank / Hood / Vac Motor

234757
DRAWING: DRW-6560 ISS: A01
16/09/2010

NB: FOR WIRING SEE DRAWING: DRW-5329

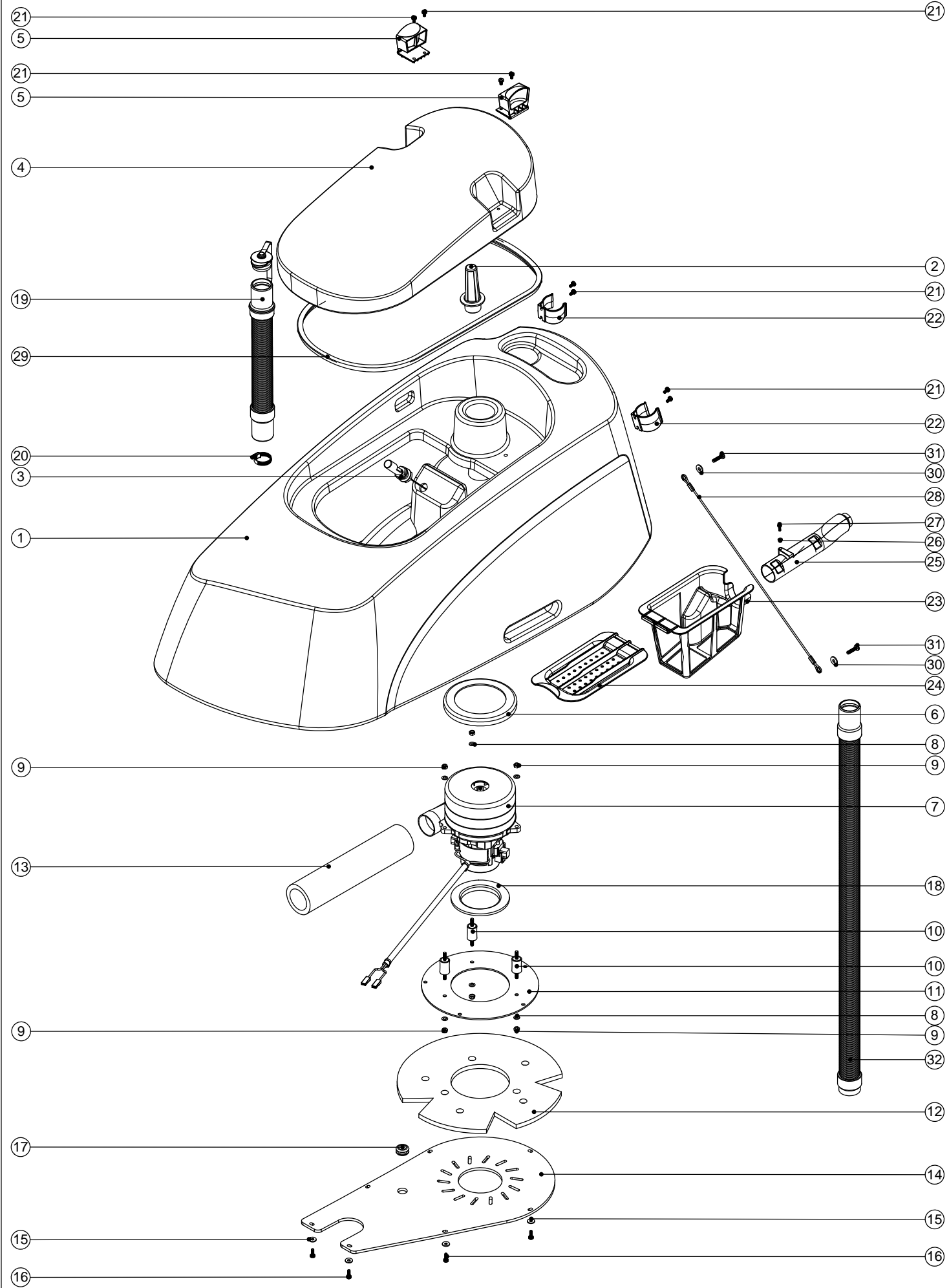

Numatic International Spare Parts

Model No: TTV5565 Top Tank / Hood / Vac Motor

POS:	ITEM NO:	DESCRIPTION:	COMMENTS:
1	237111	BLUE TOP TANK MOULDING	
2	207122	BARREL FILTER	
3	206944	FLOAT SWITCH	
4	237110	BLUE SEPARATOR HOOD MOULDING	
5	229494	CLIP MOULDING	
6	202031	BOTTOM MOTOR GASKET	
7	321593	24V 3 STAGE TANGENTIAL VAC MOTOR & 600MM LONG LEAD ASSEMBLY	
8	219007	M6 FORM B WASHER	
9	219642	M6 STAINLESS STEEL NYLON INSERT NUT	
10	208334	30MM x 20MM ANTI VIBRATION MOUNT	
11	404072	TANGENTIAL VAC MOTOR BRACKET (PAINTED GREY)	
12	208305	MOTOR PLATE SILENCER FOAM	
13	208306	SILENCER FOAM TUBE	
14	392047	VAC MOTOR BOTTOM PLATE	
15	219005	M5 FORM G WASHER	
16	219045	M5 X 16MM LONG POZI PAN SEMS SCREW	
17	208143	20MM GROMMET X 6MM PANEL THICKNESS	
18	202008	MOTOR CAP GASKET	
19	213047	38MM X 470MM LONG 3:1 STRETCH HOSE C/W CAP & STRAP	
20	206209	A.B.A HOSE CLIP	
21	219047	M5 X 10MM LONG POZI PAN SEMS SCREW	
22	229762	HOSE CLIP MOULDING	
23	208417	FILTER BASKET	
24	237173	FILTER BASKET LID	
25	237141	TOP TANK DIVERTER TUBE	
26	219688	M4 FORM A STAINLESS STEEL WASHER	
27	219890	M4 X 12MM LONG POZI PAN STAINLESS STEEL SCREW	
28	208204	495MM LONG LIFTING LINK WIRE	
29	391319	SEPERATOR SEALING STRIP	
30	219008	M6 FORM G WASHER	
31	219056	M6 X 25MM LONG POZI PAN SCREW	
32	208335	850MM LONG FLOOR TOOL STRETCH HOSE	

Numatic International Spare Parts

Model No: TTV5565 Handle Assembly

NB: FOR WIRING SEE DRAWING: DRW-5329

234756
DRAWING: DRW-6514 ISS: A01
08/09/2010

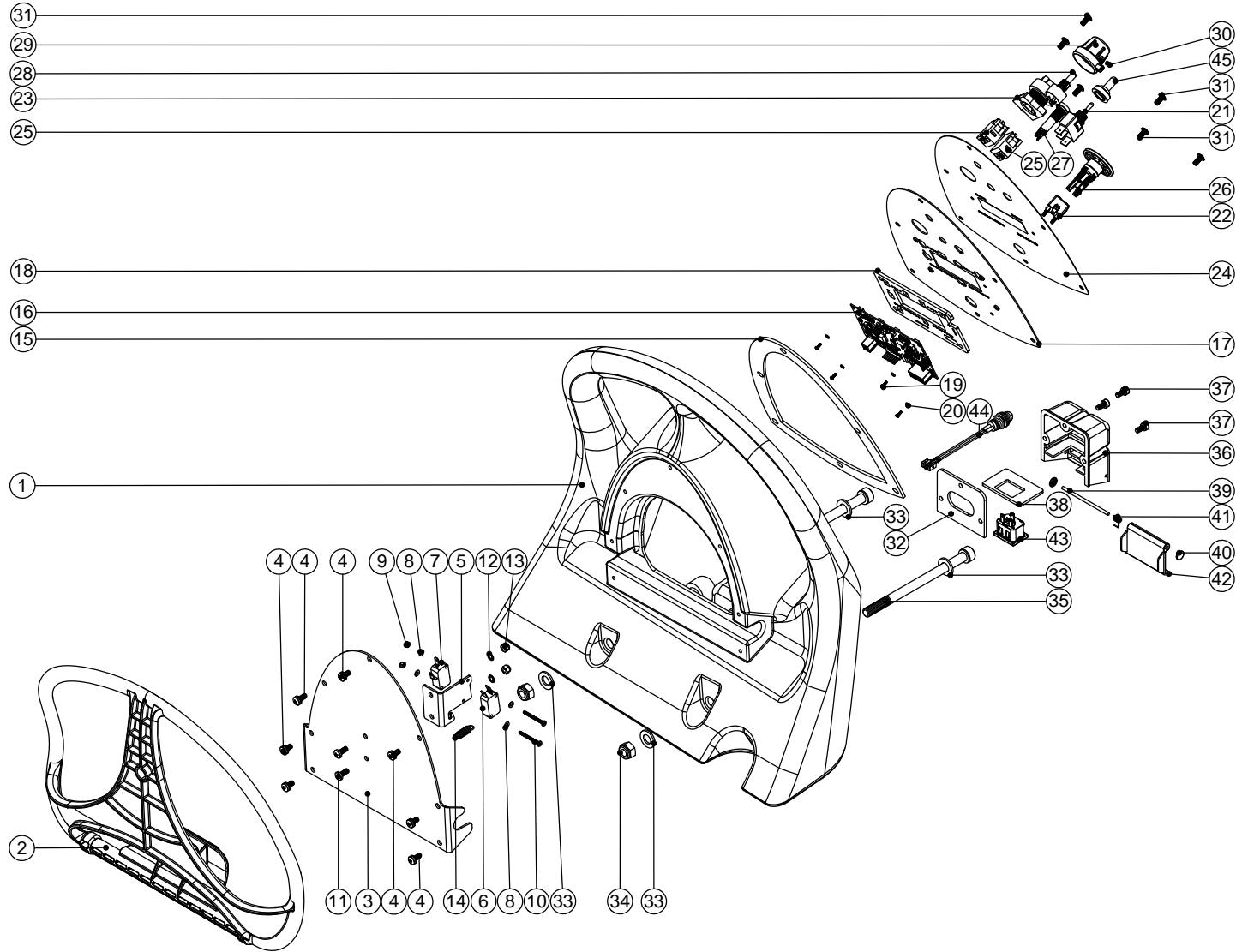

Numatic International Spare Parts

Model No: TTV5565 Handle Assembly

POS:	ITEM NO:	DESCRIPTION:	COMMENTS:
1	237113	HANDLE MOULDING	
2	237295	BLUE HANDLE TRIGGER MOULDING	
3	392053	HANDLE BACK PLATE	
4	219047	M5 X 10MM LONG POZI PAN SEMS SCREW	
5	392055	HANDLE MICRO SWITCH BRACKET	
6	229483	SNAP ACTION SWITCH	
7	208391	SNAP ACTION SWITCH	
8	219237	M3 FORM A WASHER	
9	219070	M3 NYLON INSERT NUT	
10	219611	M3 X 30MM LONG POZI PAN SCREW	
11	219049	M5 X 12MM LONG POZI PAN SCREW	
12	219016	M5 SHAKEPROOF WASHER	
13	219076	M5 NYLON INSERT NUT	
14	208356	TRIGGER SPRING	
15	208336	CONTROL PANEL PUNCHED GASKET	
16	208286	TTB5565 DISPLAY PCB	
17	303947	CONTROL PANEL C/W SELF-CLINCH NUTS	
18	392044	DISPLAY PCB PLASTIC COVER PLATE	
19	219978	M2 X 6MM LONG POZI PAN SCREW	
20	219977	M2 NYLON WASHER	
21	206786	SWITCH	
22	208458	SWITCH BLOCK (DOUBLE POLE / 2 POSITION) (A0152B)	
23	208138	KEY SWITCH (2 POSITION)	
24	208326	CONTROL PANEL OVERLAY	
25	208137	KEY SWITCH ACTUATOR BLOCK	
26	208357	EMERGENCY STOP 40MM DIAMETER BUTTON	
27	270291	GREEN LED INDICATOR 2V C/W 2.2K RESISTOR	
28	270294	POTENTIOMETER	
29	329363	SPEED ADJUSTMENT KNOB C/W INSERT	
30	219744	M4 X 6MM LONG BLACKODISED GRUB SCREW	
31	291004	M5 X 10MM LONG STAINLESS STEEL BUTTON HEAD SCREW	
32	202105	SOCKET COVER SEALING GASKET	
33	219012	M10 FORM E WASHER	
34	219649	M10 NYLON INSERT NUT	
35	291001	M10 X 150MM LONG SOCKET CAP SCREW BLACKODISED	
36	303629	SOCKET COVER MOULDING C/W LARGE MOULDED HOLE (WITH PROCESSED HOLES)	FLAME RETARDENT CSA SPEC STANDARD
37	291013	M5 X 10MM LONG SOCKET CAP SCREW	
38	329297	SOCKET MOUNTING PLATE	
39	390979	72MM LONG X 3MM DIAMETER STAINLESS STEEL BAR	
40	219832	3MM DIAMETER STARLOCK	
41	219819	TORSION SPRING	
42	227781	FLAP MOULDING	
43	220391	3 PIN APPLIANCE SOCKET	
	270195	NEON INDICATOR RED LENS 120V C/W LINK WIRES	
44	270193	NEON INDICATOR RED LENS 230V C/W LINK WIRES	
45	206785	SWITCH COVER C/W NUT	

Numatic International Spare Parts

Model No: TTV5565 Deck Assembly

234759
DRAWING: DRW-6930 ISS: A01
17/11/2010

NB: FOR WIRING SEE DRAWING: DRW-5329

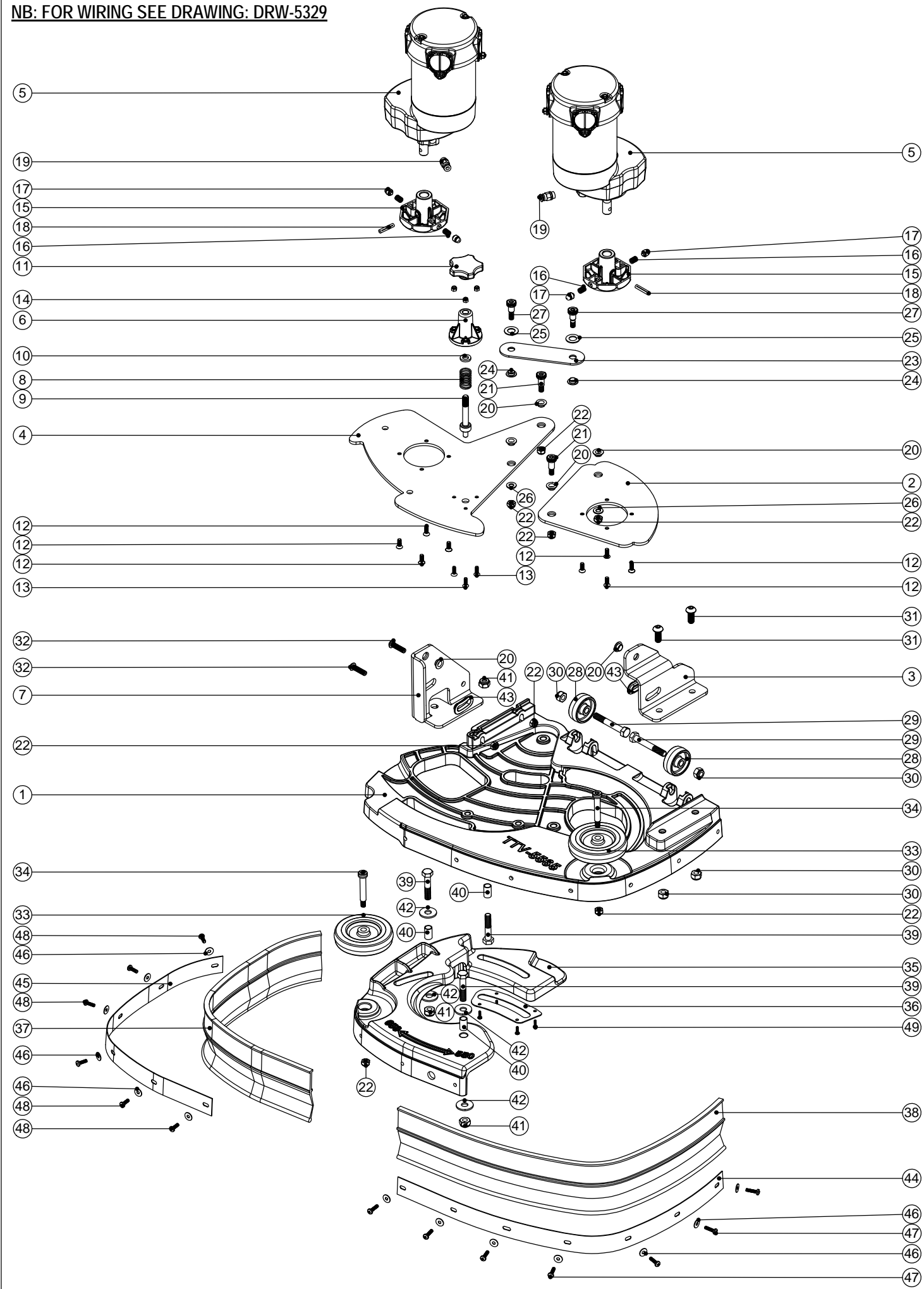

Numatic International Spare Parts

Model No: TTV5565 Deck Assembly

POS:	ITEM NO:	DESCRIPTION:	COMMENTS:
1	303955	MACHINED ALUMINIUM CAST DECK	
2	404069	LEFT HAND MOTOR PLATE (ZINC PLATED)	
3	404068	DECK LIFTING PLATE (ZINC PLATED)	
4	404070	RIGHT HAND MOTOR PLATE (ZINC PLATED)	
5	205244	AMER BRUSH MOTOR (24V-330W-200RPM)	
6	237221	INDEX PLUNGER HOUSING MOULDING	
7	404067	DECK LIFTING PLATE (ZINC PLATED)	
8	219592	COMPRESSION SPRING	
9	208352	INDEX PLUNGER PIN	
10	219964	NYLON WASHER (18MM O/D X 10.4MM I/D X 3MM THICK)	
11	208354	M10 LOBE KNOB	
12	291012	M6 X 16MM LONG COUNTERSUNK MILD STEEL Z/PL SOCKET SCREW	
13	219282	M5 X 16MM LONG POZI PAN COUNTERSUNK SCREW	
14	219076	M5 NYLON INSERT NUT	
15	206966	CHUCK CASTING	
16	206957	DRIVE SYSTEM SPRING	
17	208135	CHUCK DOME	
18	219523	GROOVED PIN	
19	208369	1/4" BSP TO 6MM PUSHFIT MALE STUD	
20	208330	IGUS BEARING (GFM 101206)	
21	208332	M8 X 10 X 16 SHOULDER BOLT	
22	219857	M8 NYLON INSERT HALF NUT	
23	392070	MOTOR PLATE LINK	
24	208312	IGUS BEARING (GFM 101205)	
25	219302	M12 FORM B STAINLESS STEEL WASHER	
26	219010	M8 FORM A WASHER	
27	208313	M8 X 10 X 12 SHOULDER BOLT	
28	206712	50MM DIAMETER BLACK WHEEL	
29	219570	M10 X 70MM LONG HEX BOLT	
30	219649	M10 NYLON INSERT NUT	
31	219910	M10 X 25MM LONG SOCKET BUTTON HEAD STAINLESS STEEL SCREW	
32	219817	M8 X 30MM LONG SOCKET BOLT	
33	303942	100MM DIA WHEEL MODIFIED BORE (10.1MM DIAMETER)	
34	208333	M8 X 10 X 50 SHOULDER BOLT	
35	237114	DECK PLASTIC SIDE POD	
36	392071	SIDE POD SLIDE PLATE	
37	208324	RUBBER EXTRUDED SPLASH SKIRT (SHORT)	
38	208307	RUBBER EXTRUDED SPLASH SKIRT (LONG)	
39	219968	M10 X 50MM LONG HEX HEAD BOLT Z/PL	
40	303811	12.7MM DIAMETER X 18G X 20MM LONG STAINLESS STEEL TUBE	
41	219897	M10 STAINLESS STEEL NYLON INSERT NUT	
42	219948	M10 PENNY WASHER	
43	237162	SLIDER BUSH	
44	392114	SPLASH SKIRT RETAINING STRIP (LONG)	
45	392115	SPLASH SKIRT RETAINING STRIP (SHORT)	
46	219644	M5 FORM G STAINLESS STEEL WASHER	
47	219571	M5 X 20MM LONG POZI PAN STAINLESS STEEL SCREW	
48	219547	M5 X 16MM LONG POZI PAN STAINLESS STEEL SCREW	
49	219318	No6 X 1/2 INCH LONG POZI PAN PLASTITE SCREW	



Numatic International Spare Parts

Model No: TTV5565 Squeegee Assy (850mm Scrub Width/38mm Hose)

234781
DRAWING: DRW-6860 ISS: A01
03/11/2010

NB: FOR WIRING SEE DRAWING: DRW-5329

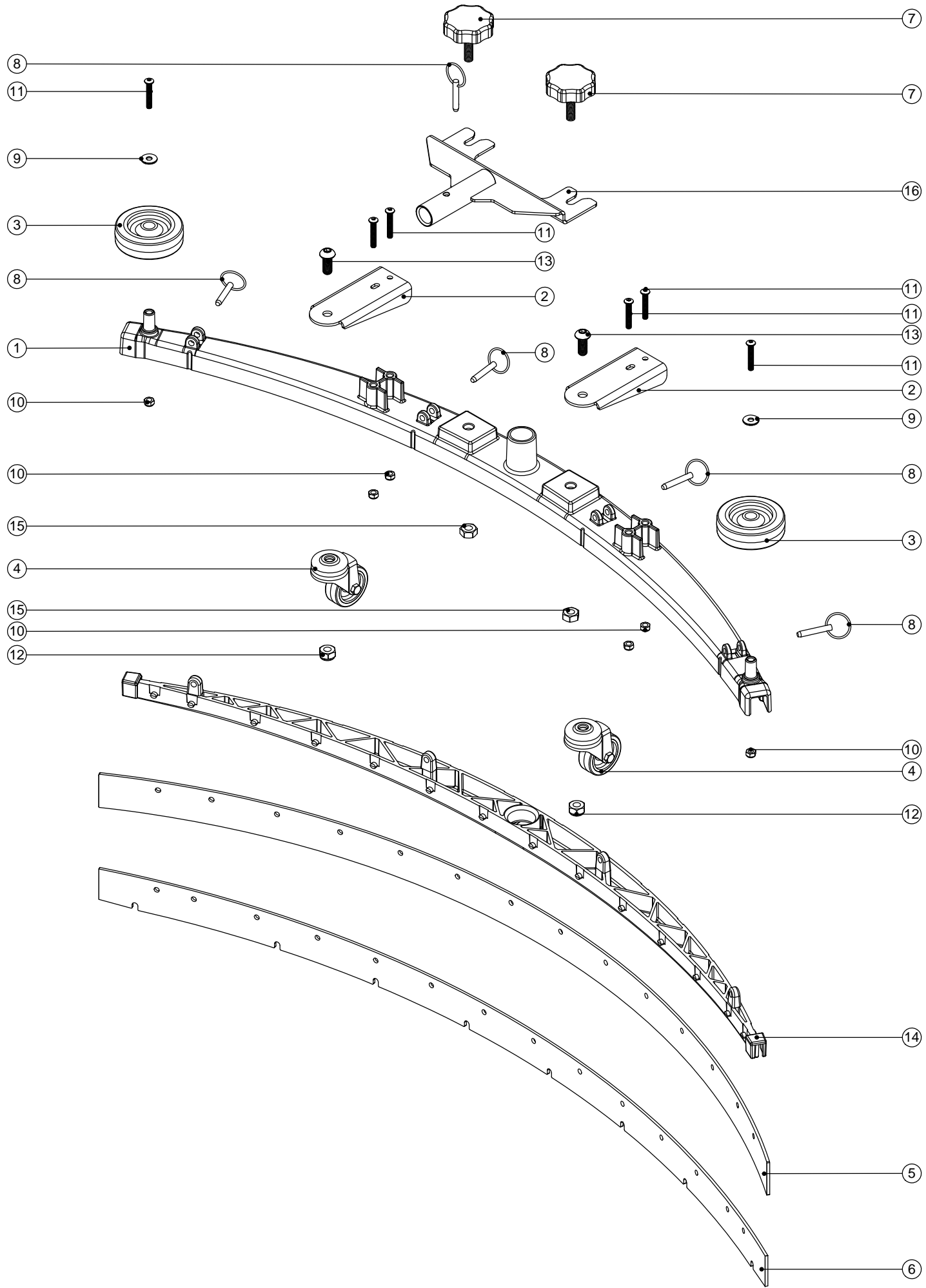

Numatic International Spare Parts

Model No: TTV5565 Squeegee Assy (850mm Scrub Width/38mm Hose)

POS:	ITEM NO:	DESCRIPTION:	COMMENTS:
1	208197	(850MM SCRUB WIDTH) ALUMINIUM SQUEEGEE CASTING (38MM HOSE FITTING)	
2	329825	CASTOR PLATE	
3	204068	3 INCH GREY WHEEL	
4	204018	50MM CASTOR/GREY RUBBER TYRE	
5	206950	(850MM SCRUB WIDTH) REPLACEMENT (3.2MM / 43 SHORE A) REAR POLY/BLADE (1117MM LONG)	STANDARD BLADE OPTION
	208195	(850MM SCRUB WIDTH) REPLACEMENT (4.0MM / 50 SHORE A) REAR POLY/BLADE (1117MM LONG)	PREMIUM BLADE OPTION
	208196	(850MM SCRUB WIDTH) REPLACEMENT (4.0MM / 40 SHORE A) REAR RED LINATEX PREMIUM NATURAL RUBBER/BLADE (1117MM LONG)	PREMIUM BLADE OPTION
6	206949	(850MM SCRUB WIDTH) REPLACEMENT (3.2MM / 43 SHORE A) FRONT POLY/BLADE (1085MM LONG)	STANDARD BLADE OPTION
	208193	(850MM SCRUB WIDTH) REPLACEMENT (3.2MM / 50 SHORE A) FRONT POLY/BLADE (1085MM LONG)	PREMIUM BLADE OPTION
	208194	(850MM SCRUB WIDTH) REPLACEMENT (3.2MM / 40 SHORE A) FRONT RED LINATEX PREMIUM NATURAL RUBBER/BLADE (1085MM LONG)	PREMIUM BLADE OPTION
7	206951	QUICK RELEASE KNOB	
8	206953	DETENT PINS	
9	219647	M6 FORM G STAINLESS STEEL WASHER	
10	219853	M6 NYLOC HALF NUT (STAINLESS STEEL)	
11	219933	M6 X 35MM SOCKET BUTTON HEAD BOLT STAINLESS STEEL	
12	219897	M10 STAINLESS STEEL NYLON INSERT NUT	
13	219910	M10 X 25MM LONG SOCKET BUTTON HEAD STAINLESS STEEL SCREW	
14	229988	(850MM SCRUB WIDTH) BLADE HOLDER Moulding (SLOPING PROFILE) (32MM & 38MM HOSE FITTING)	
15	219963	M10 STAINLESS STEEL FULL NUT	
16	303871	FLOOR TOOL LIFTING PLATE WELDED ASSEMBLY	

WIRING DIAGRAM

COMP. No
123351

DRG. No
DRW-5329

TTV5565 WIRING DIAGRAM

ISSUE	REVISION	DRAWN	APPD.	DATE
A 11	TRANSAXLE BRAKE ITEM NUMBER CORRECTED FROM 321506 TO 310031 BRAKE KIT. MOTOR CONTROLLER WAS 230202 IN ERROR.	AM	MC	16/03/2012

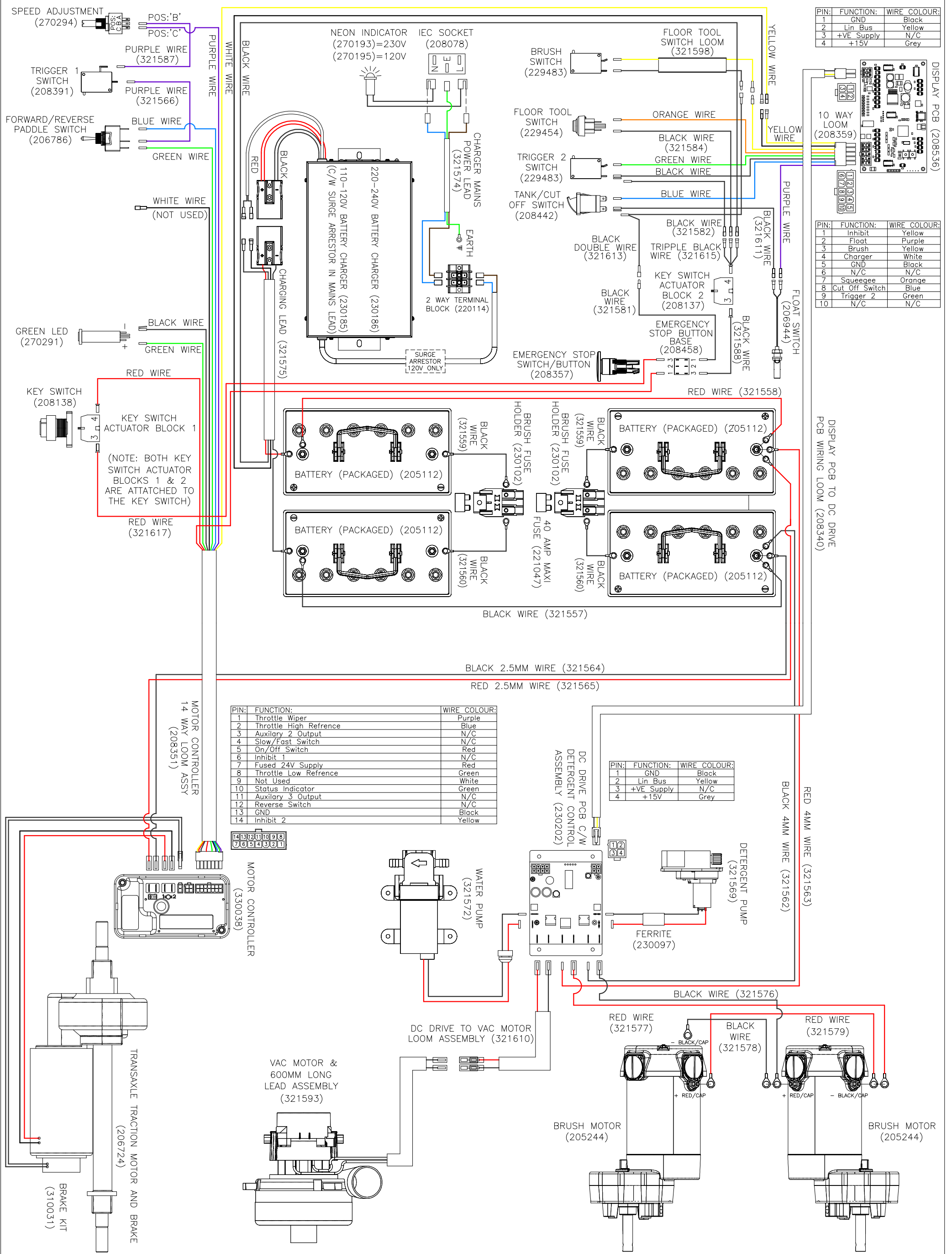

PIN:	FUNCTION:	WIRE COLOUR:
1	GND	Black
2	Lin Bus	Yellow
3	+VE Supply	N/C
4	+15V	Grey

PIN:	FUNCTION:	WIRE COLOUR:
1	Inhibit	Yellow
2	Float	Purple
3	Brush	Yellow
4	Charger	White
5	GND	Black
6	N/C	N/C
7	Squeegee	Orange
8	Cut Off Switch	Blue
9	Trigger 2	Green
10	N/C	N/C

PIN:	FUNCTION:	WIRE COLOUR:
1	Throttle Wiper	Purple
2	Throttle High Reference	Blue
3	Auxiliary 2 Output	N/C
4	Slow/Fast Switch	N/C
5	On/Off Switch	Red
6	Inhibit 1	N/C
7	Fused 24V Supply	Red
8	Throttle Low Reference	Green
9	Not Used	White
10	Status Indicator	Green
11	Auxiliary 3 Output	N/C
12	Reverse Switch	N/C
13	GND	Black
14	Inhibit 2	Yellow

PIN:	FUNCTION:	WIRE COLOUR:
1	GND	Black
2	Lin Bus	Yellow
3	+VE Supply	N/C
4	+15V	Grey

DISPLAY PCB (208536)

DISPLAY PCB TO DC DRIVE PCB WIRING LOOM (208340)

TTV 5565 Variable Speed - 50% flow rate.

WD - 10996 (A06) 15/10/2013

