

# Numatic International Spare Parts

Model No: TTQ-1535 / TTQ-3035 CHASSIS ASSEMBLY

234092  
DRAWING: EXP-0523 ISS:A09  
17/12/2008

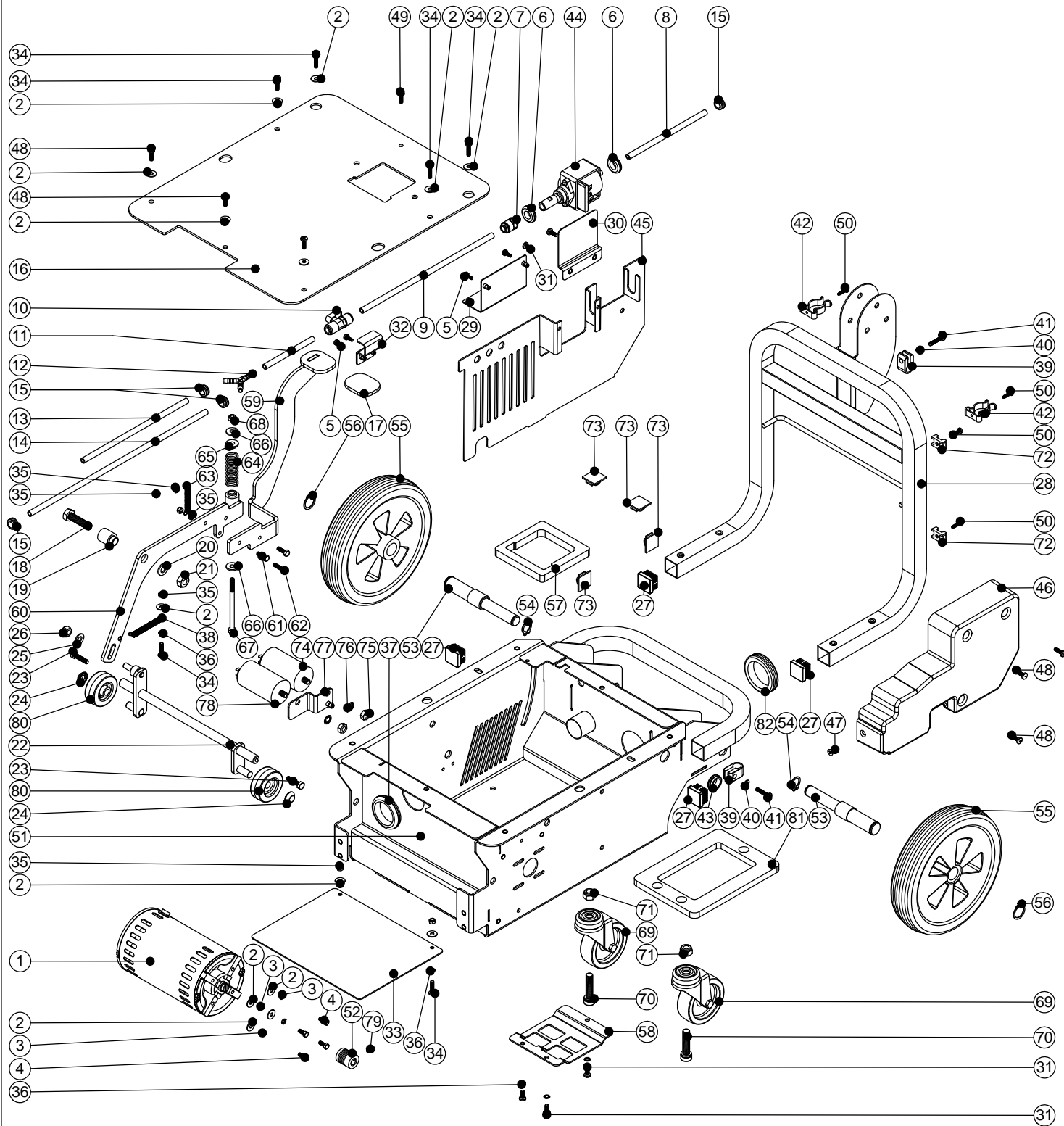

# Numatic International Spare Parts

Model No: TTQ-1535 / TTQ-3035 CHASSIS ASSEMBLY

POS:	ITEM NO:	DESCRIPTION:	COMMENTS:
1	205116	INDUCTION MOTOR 240/220V	
	205093	PSC INDUCTION MOTOR (400W) (120V) (60HZ)	
	205094	PSC INDUCTION MOTOR (400W) (115V) (50HZ)	
	205043	PSC INDUCTION MOTOR (400W) (220V) (60HZ)	
	205054	PSC INDUCTION MOTOR (400W) (100V) (50/60HZ)	
2	219644	M5 FORM G STAINLESS STEEL WASHER	
3	219648	M5 SINGLE COIL WASHER	
4	219498	M5 X 12MM LONG STAINLESS STEEL HEX SCREW	
5	219471	M4 X 12MM LONG POZI PAN SEMS SCREW	
6	219735	GROMMET	
7	216261	STRAIGHT ADAPTOR	
8	303540	160MM LONG CLEAR PVC HOSE	
9	303542	270MM LONG CLEAR PVC HOSE	
10	216260	MINI BALL VALVE	
11	303539	100MM LONG CLEAR PVC HOSE	
12	216264	EQUAL Y CONNECTOR	
13	303541	215MM LONG CLEAR PVC HOSE	
14	303543	365MM LONG CLEAR PVC HOSE	
15	219680	GROMMET	
16	329223	TOP COVER	
17	202098	FOOT PEDAL PAD	
18	219589	M10 X 40MM LONG HEX BOLT	
19	206533	PEDAL BOSS	
20	219449	M10 FORM A WASHER	
21	219074	M10 FULL NUT	
22	429066	PIVOT WHEEL WELDED ASSEMBLY PAINTED GREY	
23	219229	M6 X 25MM LONG HEX SCREW	
24	229290	3/8 INCH STAINLESS CAP	
25	219010	M8 FORM A WASHER	
26	219078	M8 NYLON INSERT NUT	
27	20662V	1 INCH SQUARE BLACK TUBE END STOP	
28	303560	HANDLE WELDED ASSEMBLY (NUTSERTED & PAINTED SILVER)	
29	303556	NUTSERTED DEFLECTOR PLATE	
30	303557	NUTSERTED SPLASH PLATE	
31	219740	M5 X 12MM LONG STAINLESS STEEL POZI PAN SCREW	
32	303555	NUTSERTED TAP BRACKET	
33	329283	WHEEL GUARD	
34	219571	M5 X 20MM LONG POZI PAN STAINLESS STEEL SCREW	
35	219633	M5 STAINLESS STEEL NYLON INSERT NUT	
36	219016	M5 SHAKEPROOF WASHER	
37	219265	GROMMET	
38	219733	EXPANSION SPRING	
39	219743	CABLE CLEAT	
40	219003	M5 FORM A STEEL WASHER	
41	219575	M5 X 25MM LONG POZI PAN STAINLESS STEEL SCREW	
42	219503	TOOL CLIP	1 CLIP FOR TTQ-1535. 2 CLIPS FOR TTQ-3035
43	219631	19MM GROMMET	
44	216303	230V / 50Hz ELKA PUMP	
	216304	120V / 60Hz ELKA PUMP	
	216285	220V / 60Hz ELKA PUMP	
	216286	100V / 50/60Hz ELKA PUMP	
45	429062	DIVIDER PLATE (PAINTED GREY)	
46	227384	BELT COVER MOULDING	
47	219405	M5 X 10MM LONG POZI PAN COUNTERSUNK SCREW	
48	219547	M5 X 16MM LONG POZI PAN STAINLESS STEEL SCREW	
49	219572	M5 X 16MM LONG POZI PAN COUNTERSUNK STAINLESS STEEL SCREW	
50	219036	No8 X 5/8 INCH LONG POZI PAN SELF TAPPING SCREW	
51	303575	NUTSERTED CHASSIS (MARK 3)	
52	206557	DRIVE PULLEY	
53	206640	AXLE	
54	229051	EXTERNAL CIRCLIP	
55	204088	8 INCH WHEEL(BLACK/GREY) 20.3MM BORE	
56	219724	20MM EXTERNAL CIRCLIP	
57	202100	TOP COVER SEAL	
58	329336	BAFFLE PLATE	
59	429073	REAR PEDAL WELDED ASSEMBLY (PAINTED RED)	
60	429072	INNER PEDAL WELD ASSEMBLY (PAINTED RED)	
61	219051	M5 X 16MM LONG HEX SCREW	
62	219546	M5 X 20MM LONG POZI PAN SEMS SCREW	
63	226093	EXTENSION SPRING	
64	226092	COMPRESSION SPRING	
65	219781	SHOULDER WASHER	
66	219008	M6 FORM G WASHER	
67	219534	M6 X 90MM LONG HEX BOLT	
68	219642	M6 NYLON INSERT STAINLESS STEEL HALF NUT	
69	204085	75MM CASTOR	
70	219782	M10 X 25MM LONG HEXAGON HEAD CAP SCREW	
71	219649	M10 NYLON INSERT NUT	
72	220904	CABLE CLIP PLATFORM	
73	220403	CABLE CLIP	
74	220876	20 MFD MOTOR RUN CAPACITOR (450V)	230V MACHINES
	220897	25 MFD MOTOR RUN CAPACITOR (450V)	220V MACHINES
	220878	50 MFD MOTOR RUN CAPACITOR (250V)	100 / 115V / 120V MACHINES
75	219079	M8 PLAIN NUT	100 / 115V / 120V MACHINES
76	219018	M8 SHAKEPROOF WASHER	100 / 115V / 120V MACHINES
77	303562	CAPACITOR BRACKET	100 / 115V / 120V MACHINES
78	220878	50 MFD MOTOR RUN CAPACITOR (250V)	100 / 115V / 120V MACHINES
79	219784	M5 X 8MM LONG BLACKODISED GRUB SCREW	
80	329339	50MM MODIFIED WHEEL	
81	202095	BOTTOM GASKET	
82	220235	FLOAT GROMMET	

# Numatic International Spare Parts

Model No: TTQ-1535/TTQ-3035 BRUSH & HOUSING ASSEMBLY

234091  
DRAWING: EXP-0522 ISS:A05  
17/12/2008

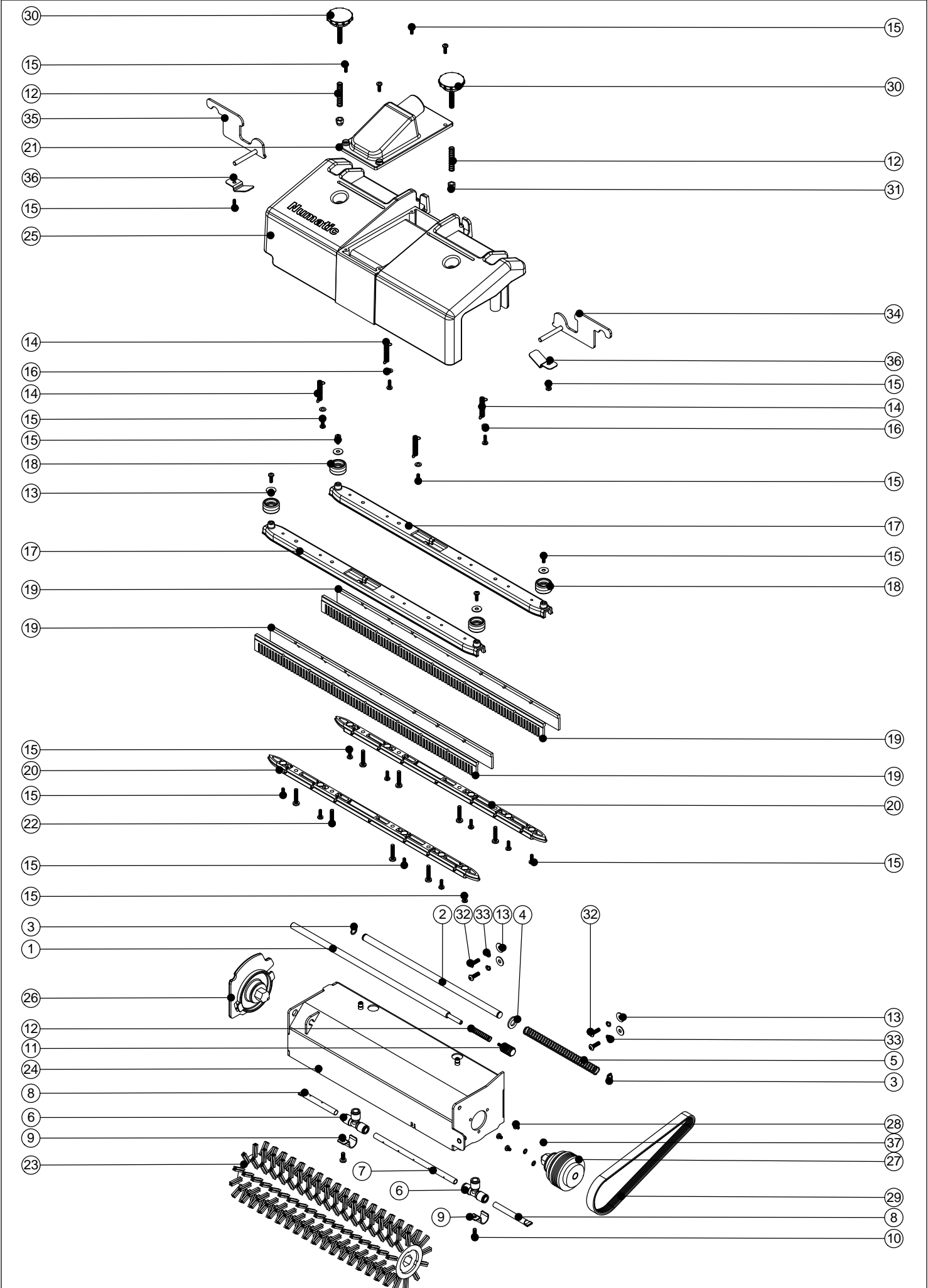

# Numatic International Spare Parts

Model No: TTQ-1535/TTQ-3035 BRUSH & HOUSING ASSEMBLY

POS:	ITEM NO:	DESCRIPTION:	COMMENTS:
1	206526	LOCKING BAR	
2	206532	COVER PIN	
3	219586	10MM EXTERNAL CIRCLIP	
4	219449	M10 FORM A WASHER	
5	219731	COMPRESSION SPRING	
6	216259	EQUAL TEE 8MM	
7	303537	SPRAY BAR MIDDLE	
8	303538	SPRAY BAR END	
9	329281	SPRAY BAR CLIP	
10	219740	M5 X 12MM LONG STAINLESS STEEL POZI PAN SCREW	
11	219738	M4 KNOB	
12	219732	COMPRESSION SPRING	
13	219644	M5 FORM G STAINLESS STEEL WASHER	
14	219734	EXPANSION SPRING	
15	219569	No8 X 1/2 INCH LONG POZI PAN STAINLESS STEEL PLASTITE SCREW	
16	219355	M5 FORM A STAINLESS STEEL WASHER	
17	227386	TOP PIECE MOULDING	
18	229389	BUFFER WHEEL	
19	217348	BLADE	
20	227387	BOTTOM PIECE MOULDING	
21	227385	AIR TUBE MOULDING	
22	219575	M5 X 25MM LONG POZI PAN STAINLESS STEEL SCREW	
23	606225	0.5MM NYLON BRISTLE SCRUB BRUSH	
24	303559	BRUSH COVER WELD ASSEMBLY	
25	318998	PRINTED BRUSH COVER MOULDING	
26	329279	END COVER MOULDING ASSEMBLY	
27	329286	DRIVE END ASSEMBLY	
28	219697	M4 X 8MM LONG POZI PAN STAINLESS STEEL SCREW	
29	217352	POLYVEE DRIVE BELT	
30	206661	HEIGHT ADJUSTMENT KNOB	
31	219764	M6 STAINLESS STEEL DOME NUT	
32	219785	M5 X 16MM LONG BUTTON HEAD STAINLESS STEEL SCREW	
33	219648	M5 SINGLE COIL WASHER	
34	329992	RIGHT HAND LIFTING LEVER ASSEMBLY	
35	329993	LEFT HAND LIFTING LEVER ASSEMBLY	
36	329291	LEVER PIN BRACKET	
37	219015	M4 SHAKEPROOF WASHER	

# Numatic International Spare Parts

Model No: TTQ-1535 / TTQ-3035 Handle Assembly

234093  
DRAWING: EXP-0524 ISS:A09  
08/12/2008

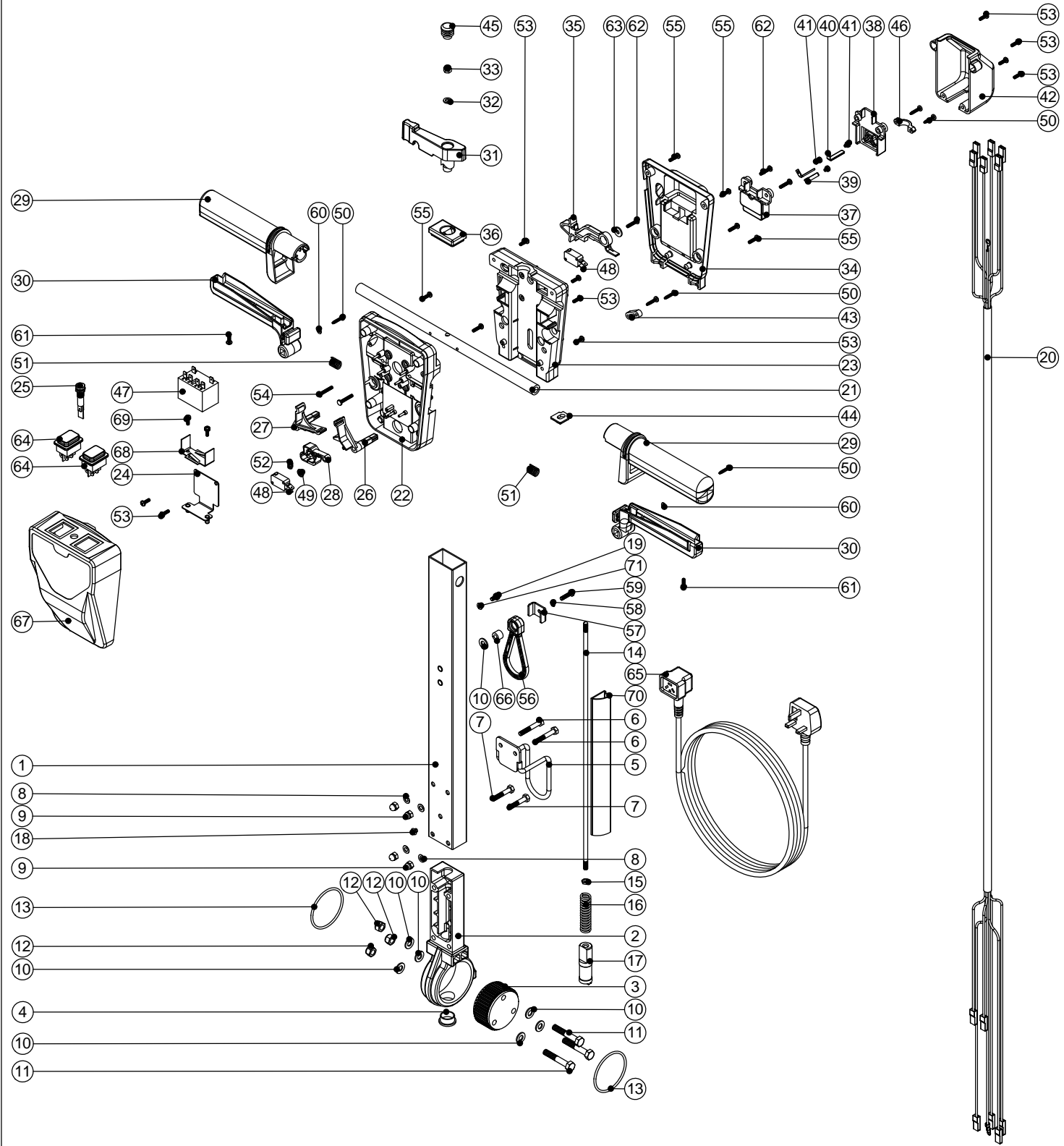

# Numatic International Spare Parts

Model No: TTQ-1535 / TTQ-3035 Handle Assembly

POS:	ITEM NO:	DESCRIPTION:	COMMENTS:
1	429074	430MM PAINTED PROCESSED ALUMINIUM HANDLE	
2	229081	HANDLE CASTING MACHINED	
3	229074	ADJUSTMENT GEAR	
4	229099	25MM DIA HOLE PLUG	
5	303498	CABLE HOOK WELDED ASSEMBLY	
6	21965V	M6 X 40MM LONG HEX BOLT	
7	219064	M6 X 35MM LONG HEX BOLT	
8	219007	M6 FORM B WASHER	
9	219080	M6 DOMENUT	
10	219010	M8 FORM A WASHER	
11	219091	M8 X 50MM LONG HEX BOLT	
12	219078	M8 NYLON INSERT NUT	
13	219254	O RING 3MM DIA X 60MM I/D	
14	229461	440MM HANDLE LOCKING ROD	
15	219099	M6 HALF NUT	
16	229138	SPRING	
17	229073	GEAR LOCKING PIN	
18	229009	BLANKING PLUG	
19	219047	M5 X 10MM LONG POZI PAN SEMS SCREW	
20	226009	7 CORE CABLE ASSEMBLY MK3	
21	338269	CROSS TUBE	
22	227576	FRONT INNER HALF MOULDING	
23	229508	FLAME RETARDENT FRONT INNER HALF MOULDING	CSA SPEC MACHINES
24	227577	REAR INNER HALF MOULDING	
25	229509	FLAME RETARDENT REAR INNER HALF MOULDING	CSA SPEC MACHINES
26	303526	NUTSERTED RELAY MOUNTING BRACKET	
27	220812	230V NEON INDICATOR & RED LENS	
28	220813	120V NEON INDICATOR & RED LENS	
29	227585	LEFT HAND SWITCH OPERATING LEVER MOULDING	
30	227586	RIGHT HAND SWITCH OPERATING LEVER MOULDING	
31	227587	CENTRE SWITCH OPERATING LEVER MOULDING	
32	227580	HAND GRIP MOULDING	
33	229500	TRIGGER MOULDING BLUE	
34	227583	ADJUSTMENT LEVER MOULDING	
35	219493	M6 NYLON WASHER	
36	219088	M6 NYLON INSERT NUT	
37	227676	REAR COVER	
38	229507	FLAME RETARDENT REAR COVER	CSA SPEC MACHINES
39	227584	INTERLOCK LEVER MOULDING	
40	227582	HANDLE PLUG MOULDING	
41	227691	TERMINAL BLOCK	
42	229510	FLAME RETARDENT TERMINAL BLOCK	CSA SPEC MACHINES
43	227680	TERMINAL BLOCK COVER	
44	229511	FLAME RETARDENT TERMINAL BLOCK COVER	CSA SPEC MACHINES
45	206562	CONTACT PIN	
46	206563	EARTH CONTACT PIN	
47	219090	M4 X 8MM LONG POZI PAN SEMS SCREW	
48	227678	SOCKET COVER	
49	229512	FLAME RETARDENT SOCKET COVER	CSA SPEC MACHINES
50	227008	BLACK CABLE CLAMP	
51	227666	BLANKING PLUG	
52	20638V	CSP-302 BLACK TUBE END STOP	
53	216290	CABLE CLAMP	
54	206575	240V / 25A RELAY	
55	206576	120V / 25A RELAY	
56	229483	SNAP ACTION SWITCH	
57	219805	4MM SPIREFIX	
58	219107	No6 X 5/8 INCH LONG POZI PAN PLASTITE SCREW	
59	219803	TRIGGER COMPRESSION SPRING	
60	219804	SWITCH COMPRESSION SPRING	
61	219569	No8 X 1/2 INCH LONG POZI PAN STAINLESS STEEL PLASTITE SCREW	
62	219811	NO8 X 1 INCH LONG POZI-PAN SELF TAP SCREW	
63	219105	No8 X 5/8 INCH LONG POZI PAN PLASTITE SCREW	
64	226008	STRESS RELIEF	
65	329231	STRESS RELIEF BRACKET	
66	219016	M5 SHAKEPROOF WASHER	
67	219054	M5 X 20MM LONG POZI PAN SCREW	
68	219206	M4 FORM A WASHER	
69	219270	No8 X 1/2 INCH LONG POZI PAN SELF TAP SCREW	
70	219568	No8 X 3/4 INCH LONG POZI PAN STAINLESS STEEL SCREW	
71	219005	M5 FORM G WASHER	
72	270146	GREEN ILLUMINATED SWITCH + MEMBRANE	
73	236012	20.0M X 1.50MM X 3 CORE NUCABLE (UK PLUG)	
74	236132	MAINS CABLE (20 METRE / 1.5MM / 3 WIRE / YELLOW CABLE / SOCKET / EURO PLUG)	
75	236020	20.0M X 1.50MM X 3 CORE NUCABLE (SWISS PLUG)	
76	236024	20.0M X 1.50MM X 3 CORE NUCABLE (SOUTH AFRICAN PLUG)	
77	236032	20.0M X 1.50MM X 3 CORE NUCABLE (AUSTRALIAN PLUG)	
78	226006	SPACER (BLACK)	
79	229748	FRONT COVER MOULDING (MAINS NO C B HOLE)	
80	229749	FLAME RETARDANT MAINS FRONT COVER MOULDING (NO C/B HOLE)	CSA SPEC MACHINES
81	206500	RELAY BRACKET	
82	219471	M4 X 12MM LONG POZI PAN SEMS SCREW	
83	391074	244MM LONG CUT SELF ADHESIVE CABLE DUCTING	
84	219003	M5 FORM A STEEL WASHER	

# WIRING DIAGRAM

ITEM No:  
123198

DRG. No  
WD-0219

## TTQ-1535 / TTQ-3035 HANDLE/VAC/BASE (230V)

ISSUE	REVISION	DRAWN	APPD.	DATE
AO4	DRAWING TITLE AMENDED TO ADD TTQ-3035 MODEL + ITEM No ADDED	AM	AM	22/12/08

(ON FRONT OF HANDLE)

